

APPLICATION NOTE

SignalOn® Series

D3.1/CCAP™
Compliant

1.2 GHz

**RF Signal Management Opportunities in
Broadband Networks**

Although every effort has been taken to ensure the accuracy of this document it may be necessary, without notice, to make amendments or correct omissions. Specifications subject to change without notice.

SignalOn® Series is a registered trademark of ATX in the United States and/or other countries. Products or features contained herein may be covered by one or more U.S. or foreign patents. Other non-ATX product and company names in this manual are the property of their respective companies.

SignalOn® Series

D3.1/CCAP™
Compliant

1.2 GHz

RF Signal Management Opportunities in Broadband Networks

Overview

Deployment of a modern broadband network provides both opportunities and challenges. Because the network is used to deliver a range of services beyond CATV, it must be both versatile and highly reliable. A flexible design allows reconfiguration both to accommodate technological change and to meet changing business requirements. Return path and the management of return path signals used to deliver advanced services are particularly important, as is signal level management in the headend. This application note addresses these issues.

Aligning the Return Plant and Establishing Unity Gain

One of the first issues to consider is alignment of the return plant. To align the return plant of a broadband HFC system, we must establish “unity gain” of that return plant. This means that the loss between each amplifier section equals the gain in that section, i.e., a gain of 0 dB. This applies to all amplifiers – line extenders, trunk and distribution amplifiers – as well as fiber optic nodes.

If return path unity gain is not established, return path signals from some legs of the network could arrive at the fiber node return laser transmitter too hot, thereby causing distortion. Decreasing some return path signals in order to compensate for or equalize the levels may cause the carrier-to-noise level to be unacceptable.

Aligning the return path for unity gain begins at the return path transmitter/amplifier closest to the headend – typically a fiber optic node – and then proceeds out to the ends of the system. (See Figure 1.) At each return path amplifier, a signal of known power is inserted into the input port. The unit is then padded so that the power received at the headend is at the desired level.

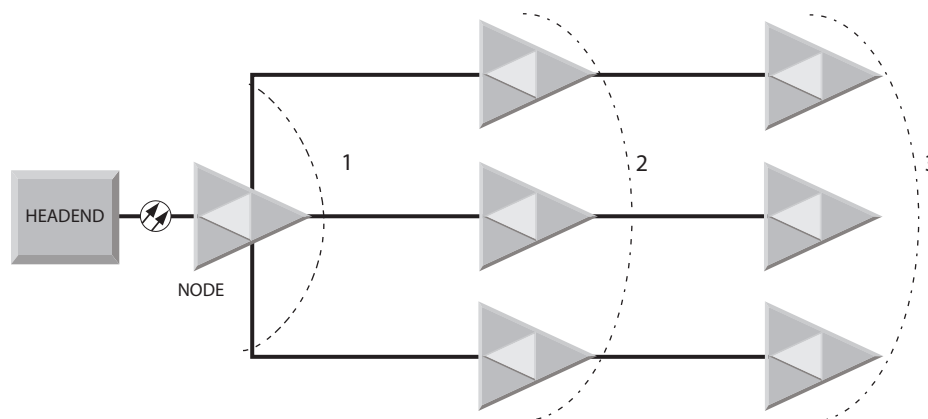

Figure #1

Figure 2 depicts a commonly used automated alignment system. This system uses a sweep signal to set up the return path signal level between a fiber optic node and the headend, and between the outside plant RF amplifiers and the headend. The test signal is inserted directly into the input of the optical transmitter. Once the signal is received at the headend, the sweep system analyzes it and sends the display information to the forward path as a narrowband digital signal. This signal is detected and displayed by the handheld field unit, verifying the optical link gain. Next the signal is inserted at the node output to set the return gain.

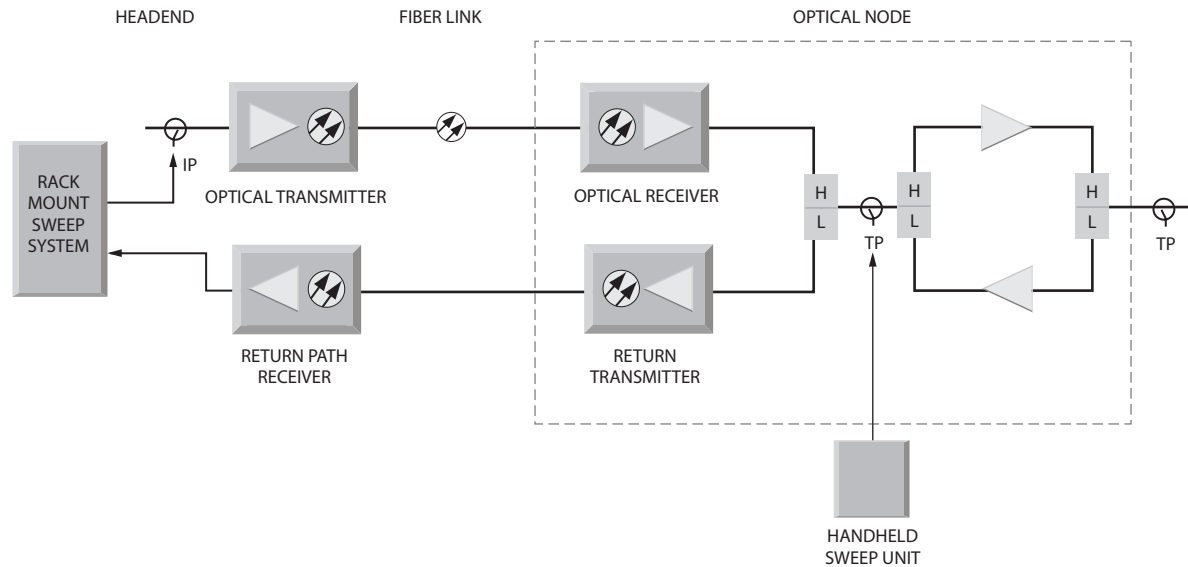

Figure #2

If the return path gain is not correct, it is adjusted to the desired level. Once correctly set, this gain reading becomes the unity gain reference for the system. The technician then moves to the next amplifier and inserts the same test signal. That return amplifier is adjusted as closely as possible to the unity gain reference, and the process is repeated at each amplifier location until the system has attained unity gain.

Deploying for Interactive Services

The modern broadband network is designed to support a variety of services. Once the system has been balanced, the return path signal must be distributed to each receiver supporting these services within the headend. This entails more than simply splitting and combining the signal. It also requires care in providing adequate signal level and C/N to each receiver.

Signal Level

Whether used for cable modem, set-top terminal, telephony device or status monitoring equipment, each service receiver requires a specific signal level for proper operation. Once the signal leaves the fiber receiver, it is usually split by a four-way or eight-way splitter. The splitter provides a port through which each service is fed to its respective receiver. (See Figure 3.) These ports can also provide return path access for new services in the future.

In some instances, return path signals from several nodes may be combined before being sent to the service receiver. This allows more efficient use of the service receiver. It also simplifies reconfiguration when service take-rates exceed the capabilities of the receiver. (See Figure 4.)

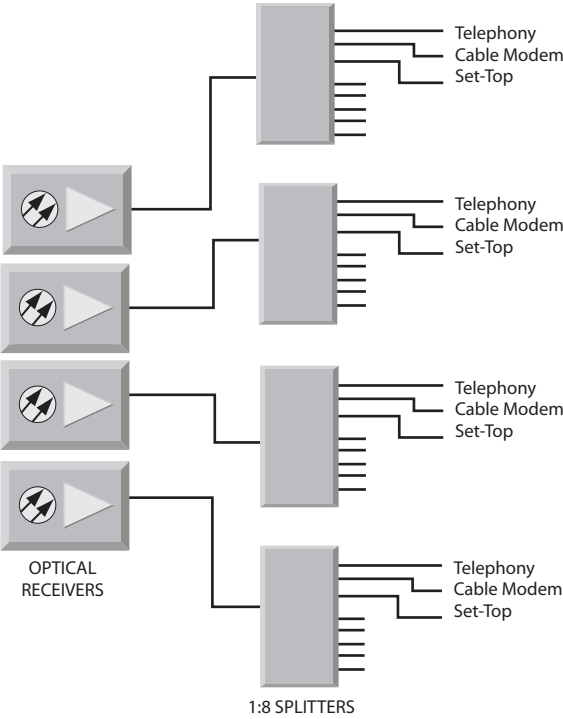

Figure #3

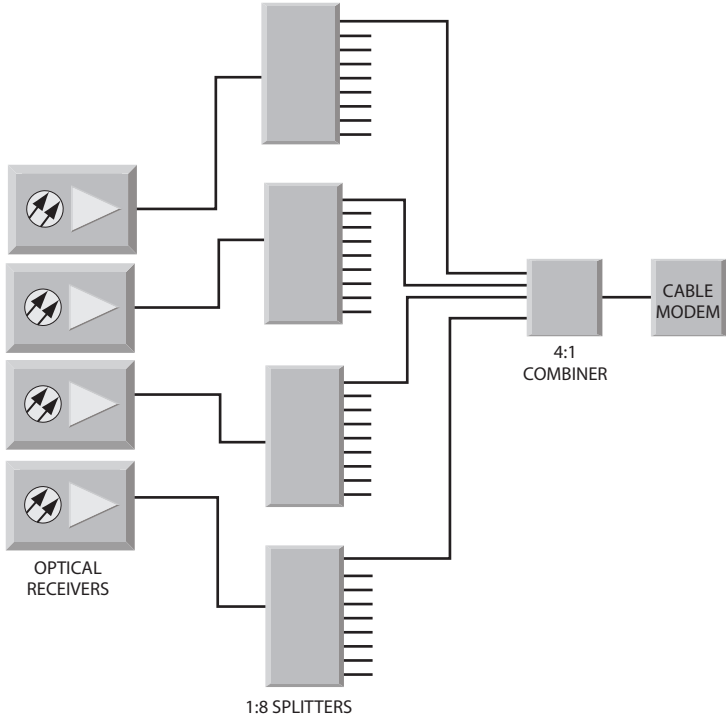

Figure #4

When attenuation is required, signal level can be reduced using attenuators or pads, rather than by adjusting the gain of fiber optic receivers or outside plant devices. Unity gain levels set in the receivers and outside plant devices provide the foundation for the return plant. Any fine-tuning (attenuation) should be done elsewhere in the plant. In the following example, attenuation is used in deployment of an interactive service, starting at the node of a properly aligned return path. The interactive service shown in Figure 5 is a cable modem system. Four nodes of service are combined at the headend. Assuming an input level of 18 dBmV at the input to the return path amplifier in the node, we find a 35 dBmV RF level out of the optical receiver at the headend. For proper operation, the input level for the cable modem equipment controller must be 0 dBmV.

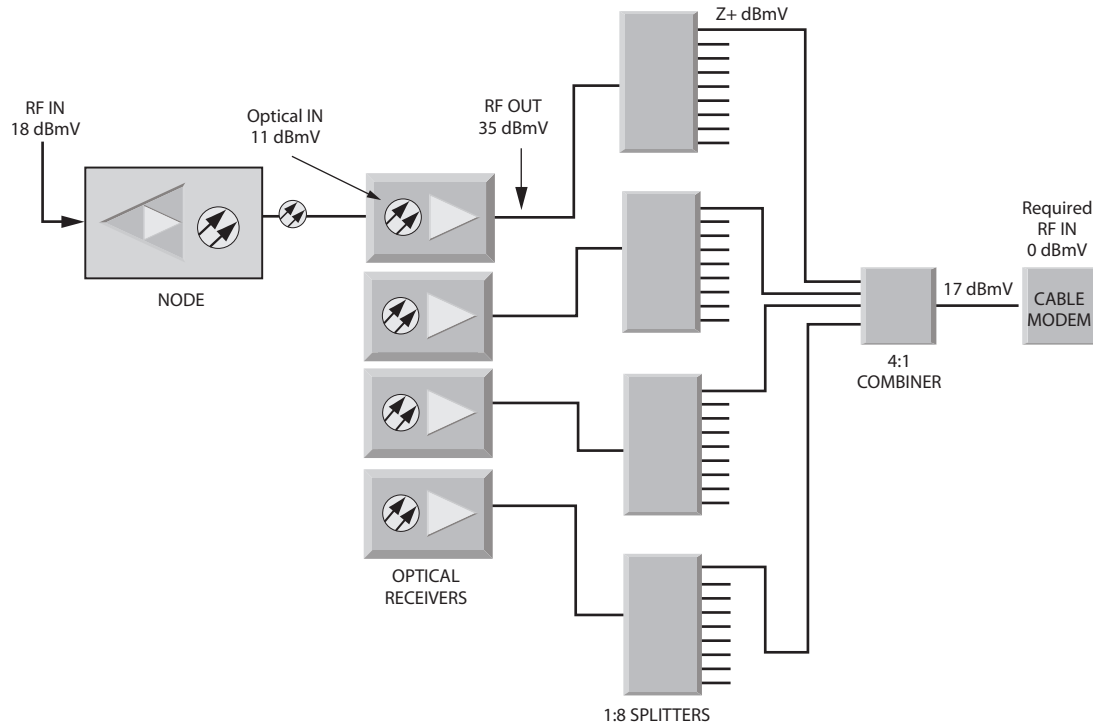

Figure #5

Note that, even with a loss of 11 dB for the eight-way splitter and 7 dB for the four-way combiner, an additional 17 dB of signal must be attenuated prior to insertion into the cable modem controller. (See Figure 6.)

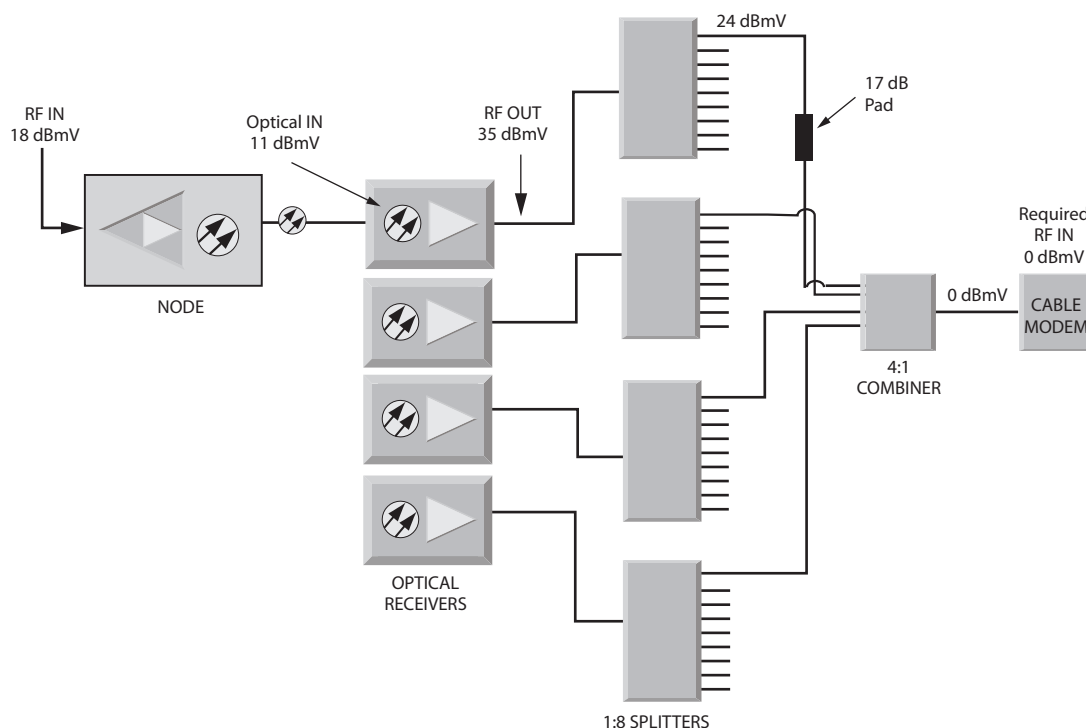

Figure #6

This can be accomplished using integrated or modular RF signal management products. This allows rapid adjustment if system parameters fluctuate – reducing downtime and increasing system availability. An RF plant is dynamic, constantly changing and alive. Environmental factors, as well as miscommunication between various engineering groups (i.e. cable modem and video), can lead to changed RF service levels and an unbalanced headend. Changing pads quickly and effortlessly – without interrupting service – is key.

C/N Performance

There are three primary sources of noise in the return path: thermal, fiber optic link and ingress. Thermal noise is caused by active components like amplifiers. The noise is caused by thermal fluctuations in the device and is characterized by the noise figure of the device. Fiber optic link noise comes from a number of sources including the fiber transmitter, the receiver, and the fiber itself. The most common source is usually ingress. Unlike the other two sources, ingress can be difficult to control since it is most often introduced within the subscriber's home. It can result from poorly or non-terminated connections, which allow the entrance of noise from hair dryers, vacuum cleaners, and RF sources such as ham radio. There have been documented cases of optical nodes and amplifiers being completely overwhelmed by nearby arc welding machines.

Ingress is the "X-factor" in signal integrity, and must be managed once it finds its way to the headend. Unfortunately, once in the return signal path, ingress noise cannot be removed. Until its source or entry point into the system is found and corrected, it must be isolated. The problem is compounded when several return path signals are combined at the headend prior to being sent to the service receiver. Strategic location of monitor points within the headend is the first line of defense.

System Test Points

It is important to have monitor points near the output of each optical receiver and after signal combining. These allow the operator to quickly isolate a problem node and take corrective action. (See Figure 7.) Speedy isolation of ingress noise is important since the first indication of a problem may be the subscriber's inability to use the service.

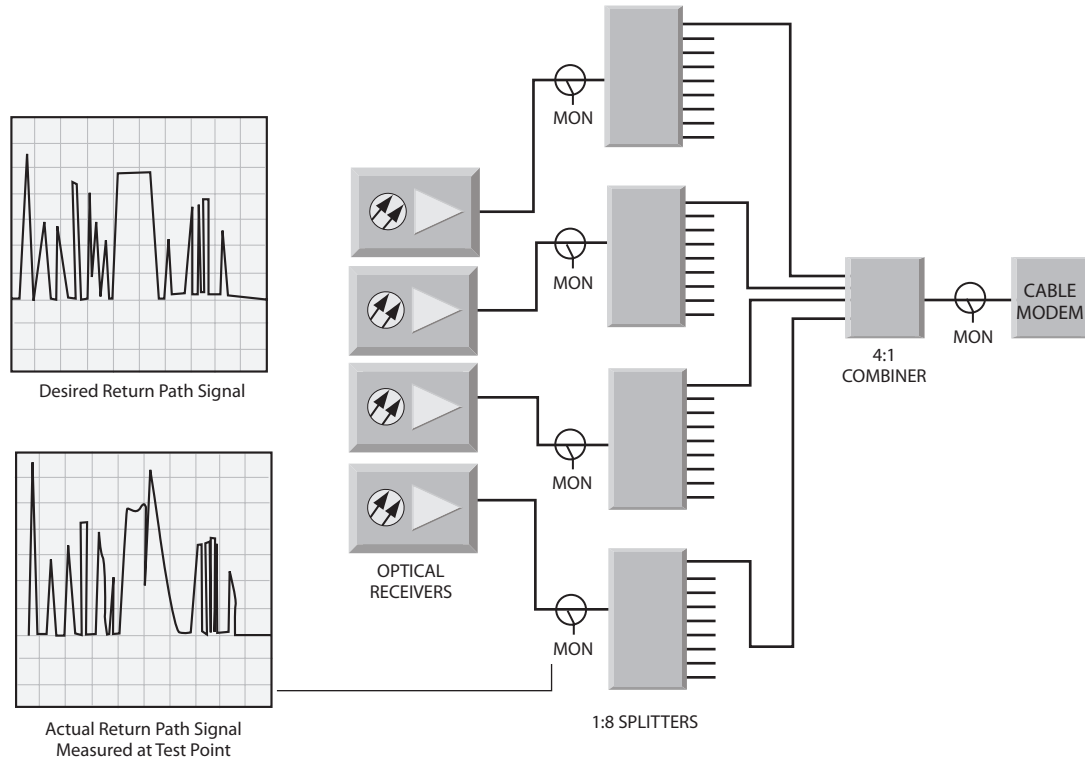

Figure #7

Although most optical return path receivers come equipped with built in test points, there are several reasons not to use them. The first is a possible difference in connectivity. For example, the receiver might use an SMA or BNC interface while the rest of the headend uses F connectors. This difference would require either specialized test cables or adapters. The second and more costly reason is possible damage to the receiver test port, forcing replacement of the entire optical receiver, entailing cost for both equipment and downtime. It is preferable to use the test port on a passive device such as a splitter/combiner or directional coupler. If this port is damaged, the device can be easily and inexpensively replaced.

Amplification

Complex broadband networks often require much more than just passive combining and splitting. Passive components can attenuate forward or return path signals, making amplification necessary. If amplifiers are required, they should allow monitoring of input and output signals and minimize contributed noise. Modularity and redundant powering are also important for maximum system availability.

Figure 8 shows a return path using SignalOn splitter/combiner products with integrated monitoring and padding. The example is a DOCSIS-compliant cable modem broadband network. Integrated splitter/combiners with monitoring and attenuation are used to manage the return path signal and aid in insertion of the signal in the forward path.



© 2020 by ATX Networks Corp. and its affiliates (collectively "ATX Networks Corp."). All rights reserved. This material may not be published, broadcast, rewritten, or redistributed. Information in this document is subject to change without notice.

Rev. 01/20 (ANW0852)



ATX Networks

Tel: 289.204.7800 | Toll-Free: 866.YOUR.ATX (866.968.7289) | support@atx.com

www.atx.com