

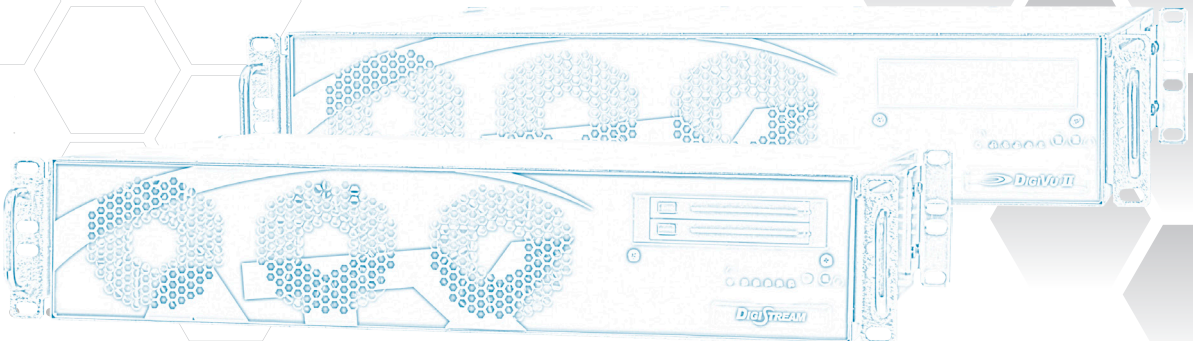

End-of-Sale as of
March 31, 2017

DigiVu[®] II
DIGISTREAM

2RU Hardware Interface Manual



General Guide Notes

Document Number **ANW1138**
Manual Release Date **October 28 2016**

Cross Reference Hyperlink Usage

Hyperlinks are used throughout the guide to assist the reader in finding related information if the reader is viewing the Adobe PDF file directly. Hyperlinks may be identified by their blue text. Most links are to related pages within the document, but some reference outside documents if the reader needs that additional information. The Table of Contents is entirely hyperlinked and bookmarks are available but the bookmark feature must be turned on in your Reader application.

Symbol Usage

Throughout the manual, some symbols are used to call the readers attention to an important point. The following symbols are in use:



NOTE: *This symbol usage will call the reader's attention to an important operation feature of the equipment which may be safety related or may cause a service outage.*



FYI: *This symbol indicates that there is helpful related information available in this note or elsewhere in the guide.*

Although every effort has been taken to ensure the accuracy of this document it may be necessary, without notice, to make amendments or correct omissions. Specifications subject to change without notice.

DigiVu® II and DigiVu® are registered trademarks of ATX in the United States and/or other countries. Products or features contained herein may be covered by one or more U.S. or foreign patents. HDM1® and other non-ATX product and company names mentioned in this manual are the property of their respective companies.

TABLE OF CONTENTS

End-of-Sale as of
March 31, 2017

GENERAL GUIDE NOTES	ii
1. <u>DEVICE OVERVIEW</u>	1-1
1.1 <u>Chapter Contents</u>	1-1
1.2 <u>Front Panels</u>	1-1
1.3 <u>Device Initial Configuration</u>	1-2
1.4 <u>System Power Supplies</u>	1-3
1.5 <u>Support for IPMI</u>	1-3
2. <u>CAPTURE CARDS</u>	2-1
2.1 <u>Chapter Contents</u>	2-1
2.2 <u>1 Channel - HDMI® or Component or CVBS</u>	2-1
2.3 <u>4 Channel - CVBS</u>	2-2
3. <u>REAR PANELS</u>	3-1
3.1 <u>Chapter Contents</u>	3-1
3.2 <u>Generic Rear Panel</u>	3-1
3.3 <u>Generic Rear Panel Connections</u>	3-1
3.4 <u>DigiStream with QAM Output</u>	3-2
3.5 <u>DigiStream LITE with QAM Output</u>	3-3
3.6 <u>DigiStream with IP Output</u>	3-4
3.7 <u>DigiVu® II IP Output</u>	3-5
4. <u>INSTALLATION</u>	4-1
4.1 <u>Chapter Contents</u>	4-1
4.2 <u>Preparation for Installation</u>	4-1
4.3 <u>Precautions</u>	4-1
4.4 <u>General Mechanical</u>	4-2
4.5 <u>Gigabit Ethernet Ports</u>	4-2
4.6 <u>Install the Chassis in a Rack</u>	4-3
4.7 <u>Equipment Safety Grounding</u>	4-4
4.8 <u>Power Supplies</u>	4-5
4.9 <u>Ethernet Cabling</u>	4-6
5. <u>STARTUP</u>	5-1
5.1 <u>Management Computer</u>	5-1
5.2 <u>Connecting to Your Computer</u>	5-1
6. <u>SAFETY</u>	6-1
7. <u>SERVICE & SUPPORT</u>	7-1
7.1 <u>Contact ATX Networks</u>	7-1
7.2 <u>Warranty Information</u>	7-1

This page intentionally left blank.

DEVICE OVERVIEW

1. Device Overview

The DigiVu® II and DigiStream 2RU series, referred to as Devices in this manual, are built in identical chassis but with different input and processing capabilities. Each model, while very similar in layout, may be identified by its unique front panel labelling.

- DigiVu II is an encoder using Analog and SDI input Capture Cards for content.
- DigiStream is a EPG creation and content streaming device (but may also have Analog Capture Cards installed).

Installation and network and Capture Card connections for each device are similar and are covered in this manual.

1.1 Chapter Contents

- [“Front Panels”](#)
- [“Device Initial Configuration”](#)
- [“System Power Supplies”](#)
- [“Support for IPMI”](#)

1.2 Front Panels

The front panels are similar on all 2RU products.

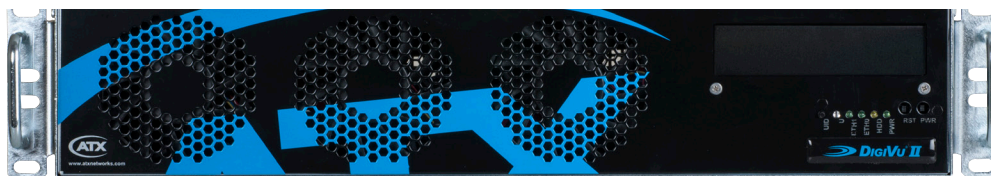

Figure 1-1: DigiVu® II Front Panel

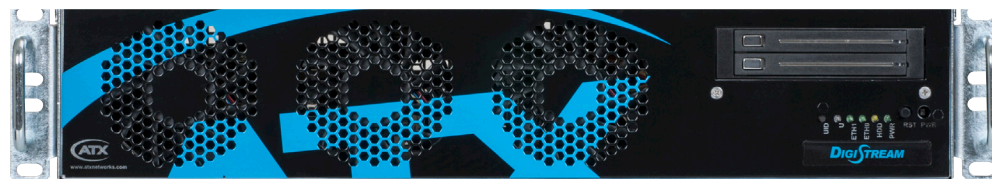

Figure 1-2: DigiStream Front Panel

1.2.1 Controls & Indicators

The products are designed to be plug and play and will be in a powered on state when the power cord is plugged in. There may be instances where it is desired to reboot or power down the devices manually and recessed switches to enable that are located on the front panel. Indicator lights are provided to allow monitoring of errors and alarms, See Table 1.2a for functional descriptions of front panel controls and indicators.

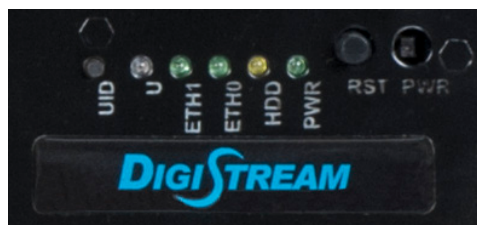

Figure 1-3: Front Controls & Indicators

Table 1.2a: Front Panel Controls and Indicators

Panel Label	Function	Description
UID	Button	Universal Identifier: A switch that will turn on the adjacent “U” light.
U	Indicator LED Blue	<p>Universal Information LED: The Universal Information BLUE LED is used to indicate fan failure, power failure, overheat condition, or to identify the unit within a large rack installation. This may be activated by the IPMI or front panel button.</p> <p>State Indication:</p> <ul style="list-style-type: none"> • Fast Blinking Red (1 per sec) - Fan Failure • Solid Red - CPU Overheated • Slow Blinking Red (1 per 4 sec) - Power Failure • Solid Blue - Local UID Button Depressed • Blinking Blue - IPMI Activated UID <p>Note: Deactivating the UID LED must be performed in the same way it was activated. (If the UID LED was activated via IPMI, you can only turn the LED off via IPMI and not with the UID button.)</p>
HDD	Indicator LED Green	Indicates SSD/HDD drive activity when flashing.
PWR	Indicator LED Green	Indicates power is being supplied to the system’s power supply units. This LED should be illuminated when the system is operating.
RST	Recessed Button	Used to reboot the encoder.
PWR	Recessed Button	The main power switch is used to apply or remove power to the encoder. Activating this switch effectively turns the encoder off but keeps standby power supplied to the system. You must unplug the system before servicing. Press again to power up.

1.3 Device Initial Configuration



NOTE: Each individual Device must have default Management (ETH0) port IP address changed from 192.168.0.23 before connecting them to the Management Switch.

Each of the Devices are factory configured with identical ETH0 Management Port IP addresses. It is important to understand that the standard ATX Networks default IP address of 192.168.0.23 for the MGMT port is assigned to all products. Before connecting each management port MGMT (ETH0) to the management switch, the IP addresses must be re-configured.

1.4 System Power Supplies

1.4.1 Standard AC Power Supply

Each Device chassis includes a high reliability, high-efficiency power supply, Figure 1-4, rated at 700 Watts.

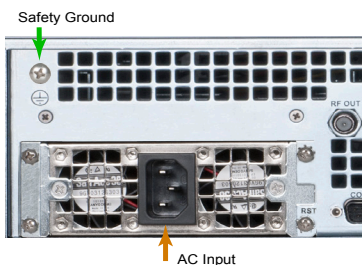

Figure 1-4: Single AC Power Supply

1.4.2 Redundant Power Option

Optionally, a redundant backup power supply pair, Figure 1-5 each rated at 700 watts may be ordered. In the unlikely event one of the redundant power supplies fail, replacement is simple and can be accomplished without tools.

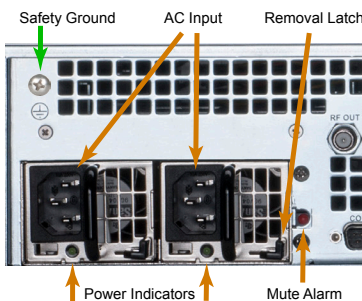

Figure 1-5: Redundant AC Power Supplies

1.5 Support for IPMI

The Intelligent Platform Management Interface is an standards based interface used by some system administrators to remotely manage server hardware in an out of band fashion, that is, irrespective of the installed operating system or BIOS of the sever. Each DigiStream or DigiVu II platform has a dedicated IPMI network port enabled with DHCP. IPMI Version 2.0 has been implemented on all products. More information may be obtained from the SUPERMICRO® support site or the following links to the available IPMI software and manuals.

- SUPERMICRO® IPMIview software <ftp://ftp.supermicro.com/utility/IPMIView/>
- The IPMI User Guides http://www.supermicro.com/manuals/other/Embedded_BMC_IPMI.pdf
http://www.supermicro.com/manuals/other/SMT_IPMI_Manual.pdf
- IPMIView Software Manual <http://www.supermicro.com/manuals/other/IPMIView20.pdf>
- Command Line Interface tool ftp://ftp.supermicro.com/utility/SMCIPMITool/SMCIPMITool_User_Guide.pdf



NOTE: Security measures should be taken if traffic from IPMI managed equipment is connected with Internet access. For more information see <https://www.us-cert.gov/ncas/alerts/TA13-207A>

1.5.1 IPMI Dedicated LAN LEDs

In addition to the Gigabit Ethernet ports, an IPMI Dedicated LAN is also located on the Backplane. The amber LED on the right of the IPMI LAN port indicates activity, while the green LED on the left indicates the speed of the connection, Figure 1-6.

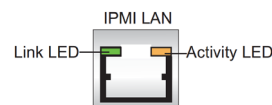

Figure 1-6: IPMI LAN Indicator

This page intentionally left blank.

CAPTURE CARDS

2. Capture Cards

Capture Cards are used to ingest analog video/audio and SDI inputs to the Devices. They may be provided with some Device models as factory ordered or added in the field. The input connections are not silk screened as to their function and not all connections are used, so this guide will show which ports to use.

2.1 Chapter Contents

- “1 Channel - HDMI® or Component or CVBS”
- “4 Channel - CVBS”

2.2 1 Channel - HDMI® or Component or CVBS



Figure 2-1: HDMI® - Component - CVBS Input Card



Figure 2-2: Multi-Input Card With Adapter Cable

Single input

- HDMI digital with embedded stereo audio on standard HDMI connector.
- Component Video on RCA with unbalanced stereo audio on RCA (BNC Adapters provided).
- Composite Video Baseband (CVBS) with unbalanced stereo audio on RCA (BNC Adapters provided).

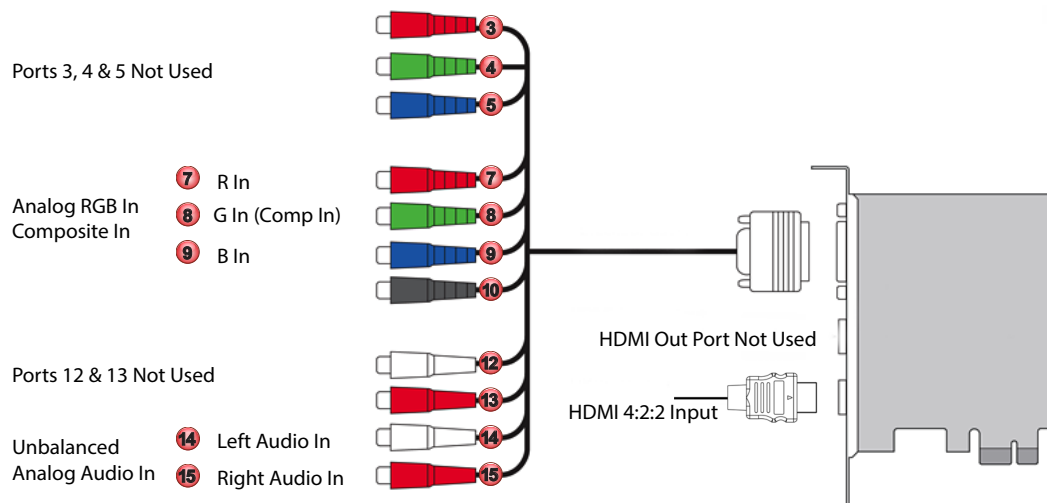

Figure 2-3: Multi-Input Card - Adapter Cable Connections

2.3 4 Channel - CVBS

Four inputs:

- Composite Video Baseband (CVBS) on BNC female jacks.
- Unbalanced Stereo on 3.5 mm TRS (Tip/Ring/Sleeve)

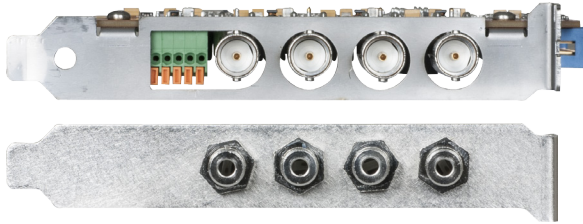

Figure 2-4: 4 Channel Analog Video/Audio Cards

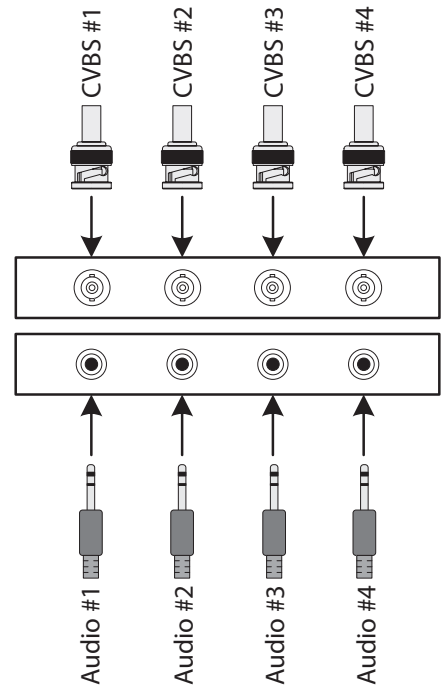

Figure 2-5: 4 Channel Video Card paired with 4 Channel Analog Audio Input Panel

TRS Audio Connections

The audio connection for the unbalanced stereo analog input is made with 3.5 mm TRS (Tip/Ring/Sleeve) plugs, the connection of which is illustrated in Figure 2-6. The installer may find that using available adapter cables to RCA, BNC or screw terminals similar to that shown in Figure 2-7 and Figure 2-8 will make interfacing easier.

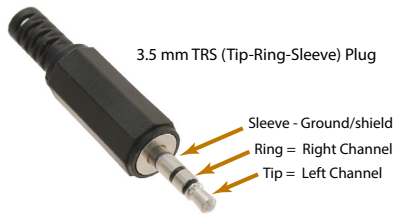

Figure 2-6: 3.5 mm TRS Connections



Figure 2-7: 3.5 mm TRS to BNC



Figure 2-8: 3.5 mm TRS to Terminals

REAR PANELS

3. Rear Panels

This chapter describes rear panel connections as the connection names are not silk screened on the panel.

3.1 Chapter Contents

- “Generic Rear Panel”
- “Generic Rear Panel Connections”
- “DigiStream with QAM Output”
- “DigiStream LITE with QAM Output”
- “DigiStream with IP Output”
- “DigiVu® II IP Output”

3.2 Generic Rear Panel

All 2RU Devices are built with the rear panel configuration shown in Figure 3-1.

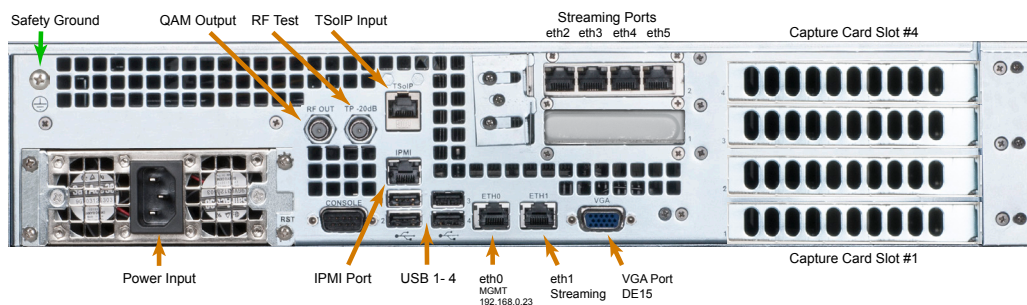

Figure 3-1: Generic Rear Panel

3.3 Generic Rear Panel Connections

All models have similar rear panel connection functionality, shown in Table 3.3a. Some models may not have all connections listed here.

Table 3.3a: Rear Panel Connections - All Models

Port	Type	Description
eth0	GbE	The Management Port used to configure the encoder. Not usually used for streaming content but could be if necessary. May also have VLAN virtual ports created.
eth1	GbE	Streaming or publishing exclusively for IP based streaming content or VLANs if configured.
eth2	GbE	Streaming or publishing exclusively for IP based streaming content or VLANs if configured.
eth3	GbE	Streaming or publishing exclusively for IP based streaming content or VLANs if configured.
eth4	GbE	Streaming or publishing exclusively for IP based streaming content or VLANs if configured.
eth5	GbE	Streaming or publishing exclusively for IP based streaming content or VLANs if configured.
RF Out	“F” Female	RF Output from QAM Modulator, if equipped.
TP -20 dB	“F” Female	Used to connect an RF test meter to monitor RF Output if equipped with QAM Modulator. This test point is 20 dB below the RF Out levels.
TSolP	Ethernet	Provides input connection to the internal QAM modulator, if equipped, and requires an Ethernet jumper installed between it and eth1.
Console	DB9	Not used in this application.
IPMI	GbE	DHCP enabled hardware level interface for encoder management supporting IPMI LAN 2.0.

Port	Type	Description
Mute Alarm	Button	This is present only on dual redundant power supply option, see Figure 1-5 . Used to temporarily disable the audible power supply alarm when one power supply or its power source have failed.
VGA	DE15	Used to connect a VGA monitor to access the MKIP system shell. MKIP may also be accessed by SSH client through eth0 port. This port is also sometimes know as DB15HD.
USB (Black)	USB 2.0	Provided to connect a keyboard and mouse if required to access the MKIP system shell.
USB (Blue)	USB 3.0	Provided to connect a keyboard and mouse if required to access the MKIP system shell.

3.4 DigiStream with QAM Output

Models with QAM output have RF Output connectors and require a TSolP input jumper.

3.4.1 DSQ40-00

No Input Channels

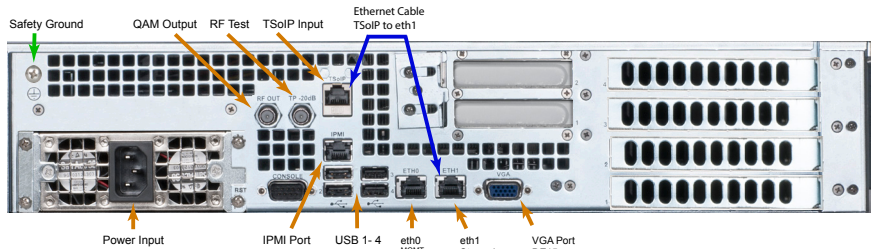

Figure 3-2: DSQ40-00

3.4.2 DSQ40-H0

1 Input Channel

Input Types

- 1 - HDMI on HDMI Female
- 1 - Component or CVBS w/Stereo Audio on DA26 Connector w/adaptor cable

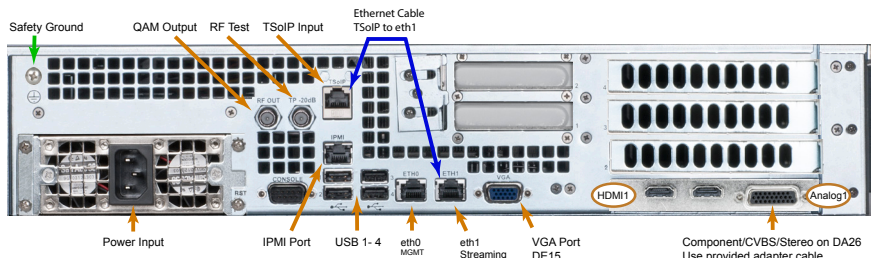

Figure 3-3: DSQ40-H0

3.4.3 DSQ40-HH

2 Input Channels

Input Types

- 2 - HDMI on HDMI Female
- 2 - Component or CVBS w/Stereo Audio on DA26 connector w/adaptor cables

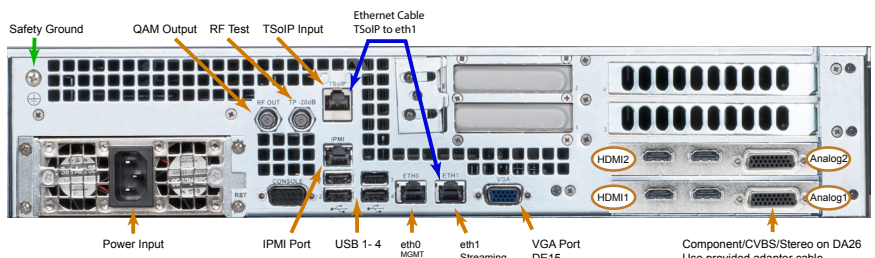

Figure 3-4: DSQ40-HH

3.4.4 DSQ40-S0

4 Input Channels

Input Types

- 4 - CVBS Video on BNC Female
- 4 - Analog Stereo Audio on 3.5 mm TRS

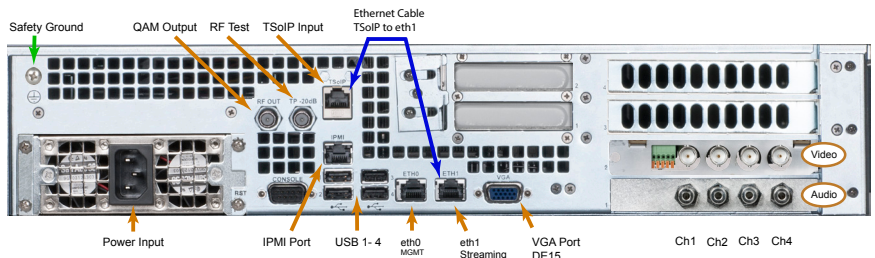

Figure 3-5: DSQ40-S0

3.4.5 DSQ40-HS

5 Input Channels

Input Types

- 4 - CVBS Video on BNC Female
- 4 - Analog Stereo Audio on 3.5 mm TRS
- 1 - HDMI on HDMI Female
- 1 - Component or CVBS w/Stereo Audio on DA26 connector w/adaptor cables

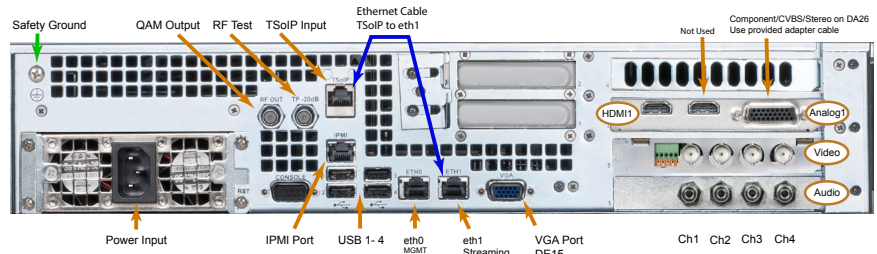

Figure 3-6: DSQ40-HS

3.5 DigiStream LITE with QAM Output

Models with QAM output have RF Output connectors and require a TSolP input jumper.

3.5.1 DSLQ20-00

No Input Channels

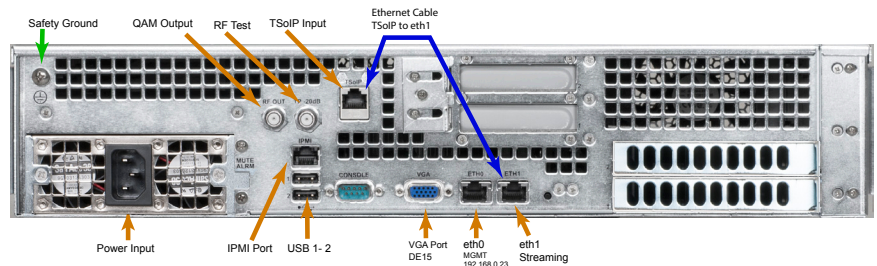

Figure 3-7: DSLQ20-00

3.5.2 DSLQ20-S0

4 Input Channels

Input Types

- 4 - CVBS Video on BNC Female
- 4 - Analog Stereo Audio on 3.5 mm TRS

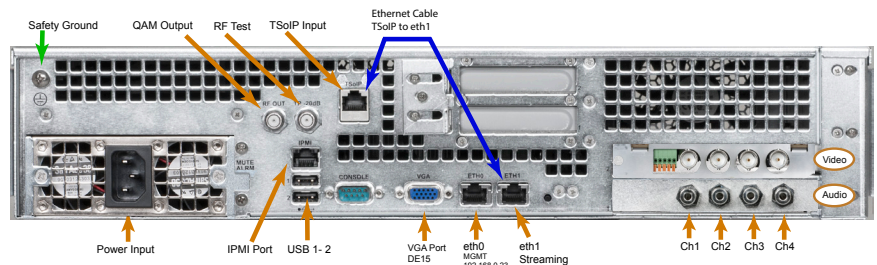

Figure 3-8: DSLQ20-S0

3.5.3 DSLQ20-H0

1 Input Channel

Input Types

- 1 - HDMI on HDMI Female
- 1 - Component or CVBS w/Stereo Audio on DA26 connector w/adaptor cable

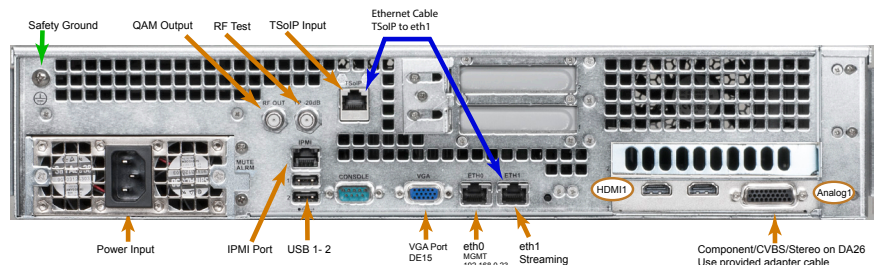

Figure 3-9: DSLQ20-H0

3.5.4 DSLQ20-HH

2 Input Channels

Input Types

- 2 - HDMI on HDMI Female
- 2 - Component or CVBS w/Stereo Audio on DA26 connector w/adaptor cables

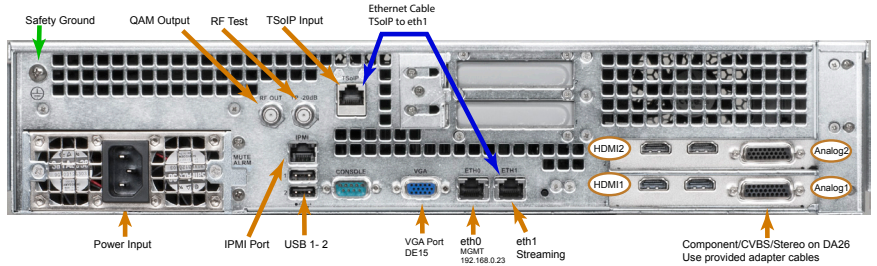

Figure 3-10: DSLQ20-HH

3.5.5 DSLQ40-HS

5 Input Channels

Input Types

- 4 - CVBS Video on BNC Female
- 4 - Analog Stereo Audio on 3.5 mm TRS
- 1 - HDMI on HDMI Female
- 1 - Component or CVBS w/Stereo Audio on DA26 connector w/adaptor cables

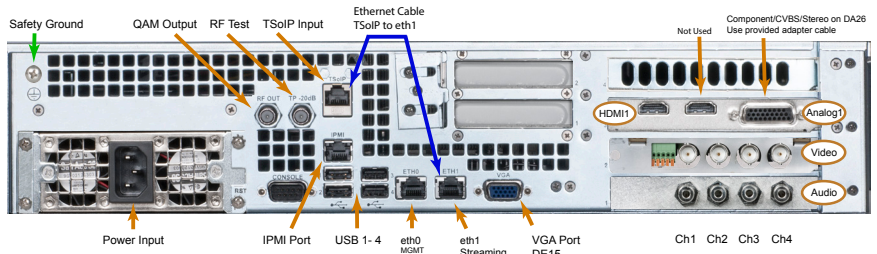

Figure 3-11: DSLQ40-HS

3.6 DigiStream with IP Output

Models with IP output have no RF Output connectors or TSolP input jumper.

3.6.1 DSI40-HS

5 Input Channels

Input Types

- 4 - CVBS Video on BNC Female
- 4 - Analog Stereo Audio on 3.5 mm TRS
- 1 - HDMI on HDMI Female
- 1 - Component or CVBS w/Stereo Audio on DA26 connector w/adaptor cables

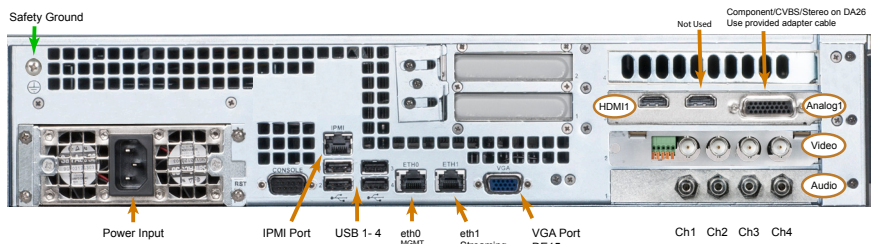

Figure 3-12: DSI40-HS

3.7 DigiVu® II IP Output

3.7.1 DVT4HDMIIP

4 Input Channels

Input Types

- 4 - HDMI on HDMI Female
- 4 - Component or CVBS w/Stereo Audio on DA26 connector w/adaptor cables

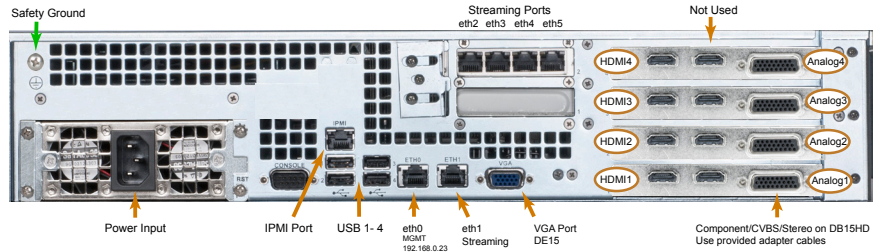

Figure 3-13: DVT4HDMIIP

3.7.2 DVT8SDAIP

8 Input Channels

Input Types

- 8 - CVBS Video on BNC Female
- 8 - Analog Stereo Audio on 3.5 mm TRS

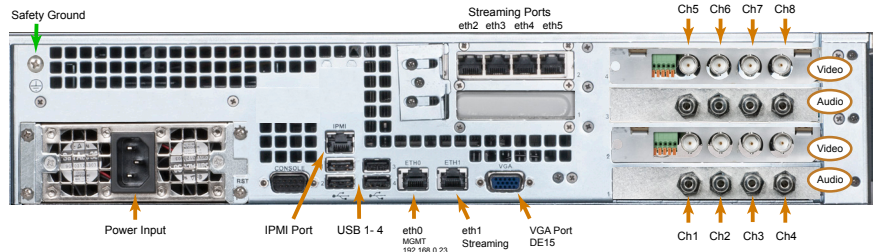

Figure 3-14: DVT8SDASIP

This page intentionally left blank.

INSTALLATION

4. Installation

This chapter provides a guide to get your Device physically installed.

4.1 Chapter Contents

- “Preparation for Installation”
- “Precautions”
- “General Mechanical”
- “Gigabit Ethernet Ports”
- “Install the Chassis in a Rack”
- “Equipment Safety Grounding”
- “Power Supplies”
- “Ethernet Cabling”

4.2 Preparation for Installation

Carefully unpack the equipment from the shipping box. If the box or equipment is damaged, notify the freight company to make a damage claim. If you suspect that there is a problem with the equipment that may preclude safe operation, do not install or operate it. Contact ATX Networks immediately for instructions.



NOTE: This equipment is intended for installation in a **RESTRICTED ACCESS LOCATION** only.



NOTE: This equipment is **NOT** for use in a computer room as defined in the Standard for Protection of Electronic Computer/Data Processing Equipment, ANSI/NFPA 75.



NOTE: This equipment is intended for use in a fixed position and should be installed securely before operation is initiated.

4.3 Precautions

4.3.1 Electrical Precautions

Basic electrical safety precautions should be followed to protect yourself from harm and the Device chassis from damage:

- Be aware of the locations of the power on/off switch on the chassis as well as the room’s emergency power-off switch, disconnection switch or electrical outlet. If an electrical accident occurs, you can then quickly remove power from the system.
- Power should always be disconnected from the system when servicing. When disconnecting power, you should first power down the operating system first and then unplug the power cords. The unit has more than one power supply cord. Disconnect two power supply cords before servicing to avoid electrical shock.
- When working around exposed electrical circuits, another person who is familiar with the power-off controls should be nearby to switch off the power if necessary.
- Use only one hand when working with powered-on electrical equipment. This is to avoid making a complete circuit, which will cause electrical shock. Use extreme caution when using metal tools, which can easily damage any electrical components or circuit boards they come into contact with.
- Do not use mats designed to decrease static electrical discharge as protection from electrical shock. Instead, use rubber mats that have been specifically designed as electrical insulators.
- The power supply power cords must include a grounding pin and must be plugged into grounded electrical outlets.
- Remove any jewelry or metal objects from your body, which are excellent metal conductors that can create short circuits and harm you if they come into contact with printed circuit boards or areas where power is present.

- This product may be connected to an IT power system. In all cases, make sure that the unit is also reliably connected to Earth (ground).

4.3.2 General Precautions

- The Device weighs up to approximately 30 lbs (14kg) when fully loaded. When lifting the system, two people should lift slowly with their feet spread out to distribute the weight. Always keep your back straight and lift with your legs.
- While working on the system, do not wear loose clothing such as neckties and unbuttoned shirt sleeves, which can come into contact with electrical circuits or be pulled into a cooling fan.
- After accessing the inside of the Device, close the chassis back up and secure it to the rack unit with the retention screws and ensure that all connections have been made.

4.3.3 Chassis Precautions

- Determine the placement of each component in the rack before you install the rails.
- Install the heaviest components on the bottom of the rack first, and then work up.
- Use a regulating uninterruptible power supply (UPS) to protect the Device from power surges, voltage spikes and to keep your system operating in case of a power failure.
- Allow any power supply modules to cool before touching them.

4.3.4 Rack Precautions

- Ensure that the leveling jacks on the bottom of the rack are fully extended to the floor with the full weight of the rack resting on them.
- In single rack installation, stabilizers should be attached to the rack. In multiple rack installations, the racks should be coupled together.

4.4 General Mechanical

- The equipment will require 2RU of vertical rack space and may be mounted directly above or below other equipment without providing space between, however, 1RU space should be maintained from other equipment which generates significant heat. Leave enough clearance in front of the rack to enable you to work on the chassis (~25 inches) and approximately 30 inches of clearance in the back of the rack to allow for sufficient airflow and ease of servicing.
- Be sure to maintain freedom of air movement around equipment. Installation of the equipment in enclosed racks is not recommended due restricted air flow. The equipment is designed to operate to specification in an ambient temperature of +10°C to +35°C (+50°F to +95°F). Normal room temperature and humidity is recommended to ensure proper long term operation of the equipment.
- Consideration should be given to the connection of the equipment to the mains power and the effect that any possible overloading of circuits might have on over current protection and wiring.
- Rear support of the unit is mandatory and rails for attachment to rear supports are provided. Do not use the unit chassis to support other equipment. Alternately, if rear support rails are unavailable or impractical, install the unit on a well supported shelf.

4.5 Gigabit Ethernet Ports

The Ethernet ports are auto-negotiating and intended to be connected to a network distribution switch using straight through wired Cat5e or better quality cable. The rear panel Management Interface eth0 port allows connection to a notebook or desktop PC for managing and configuring the system. The port may be connected to directly, or in the case of a headend with many devices to manage, may be connected to a management network (recommended) or the distribution switch containing the video stream content. It is possible to set up virtual ports for a VLAN. Connections should be made with Cat5e or better network cables. The GigE management port is auto-negotiating and should be connected to a switch or router with a straight through wired cable. Direct connection to a PC may be made with the supplied crossover cable.

4.6 Install the Chassis in a Rack

This section provides information on installing the Device chassis in a rack unit with the rails provided. There are a variety of rack units on the market, which may mean that the assembly procedure will differ slightly from the instructions provided. You should also refer to the installation instructions or adapt these instructions to suit the rack unit you are using.



NOTE: *The illustrations in Figure 4-1 and Figure 4-2 are for general guidance purposes only. Always install the Device chassis to the bottom of the rack first to avoid the rack becoming top heavy.*

4.6.1 Mount the Chassis

1. Confirm that you have the four mounting screws required to mount the chassis into a rack.
2. Align the thru holes of the chassis with the thru holes of the rack.
3. Insert the mounting screws into the thru holes in the front of the chassis and through the thru holes in the rack as shown in Figure 4-1 and Figure 4-2.

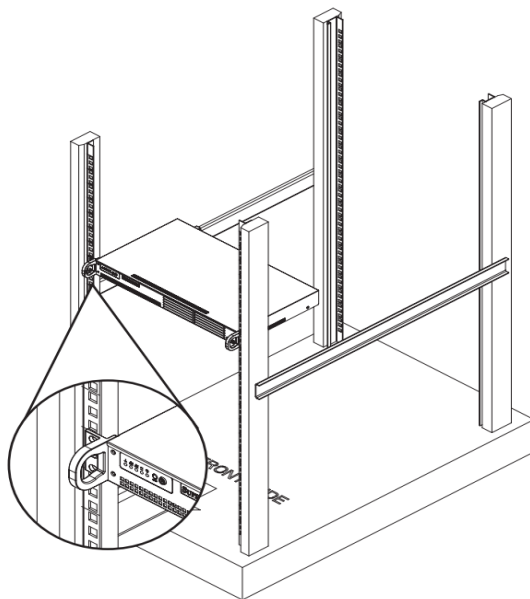

Figure 4-1: Install Chassis to Standard Rack

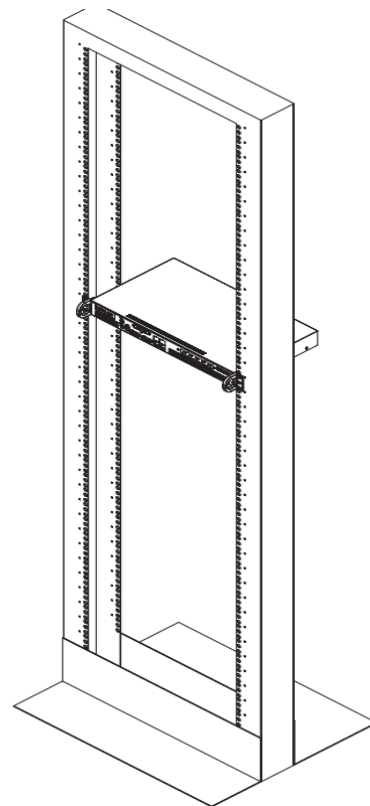

Figure 4-2: Install Chassis to Telco Rack

4.7 Equipment Safety Grounding

Reliable earthing of rack-mounted equipment should be maintained. Particular attention should be given to supply connections other than direct connections to the branch circuit (e.g. use of power strips). The following guidelines are provided to clarify the requirements for the installation to meet UL, CUL and CB standards. The use of the words “Ground” and “Earth” as well as “Grounding” and “Earthing” may be used interchangeably and in this context, have the same meaning.



NOTE: It is imperative that the encoder chassis be connected to a permanent building ground to comply with UL, CUL and CB standards.

It is important that the Device housing and power supplies be connected to a permanent building ground in a manner that will ensure that the exposed metal parts are constantly connected to ground through independent means even when the power supply cord or wires may be disconnected temporarily. Ground connections screws are provided on the rear panel to conveniently effect such a connection, Figure 4-3.

4.7.1 Ground Connection to Earth

The supplementary equipment grounding conductor is to be installed between the rear panel ground screws and earth, that is, in addition to the equipment ground conductor in the power supply cord or wires. The screw terminals provided for this connection are located on the rear panel adjacent to the power supplies and one each on the DC power supply modules (if equipped) as shown in Figure 4-3.

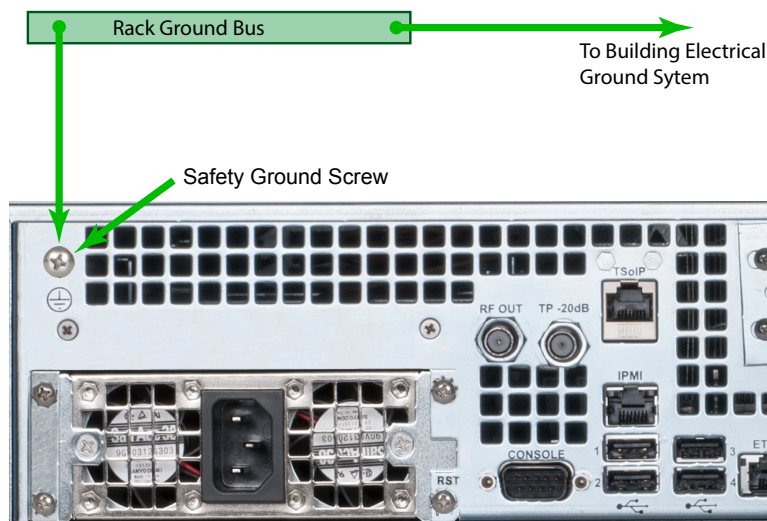

Figure 4-3: Recommended Equipment Safety Ground Connections

4.7.2 Ground Conductor Size

The supplementary equipment grounding conductor may not be smaller in size than the branch-circuit supply conductors or a minimum #14 AWG. The supplementary equipment grounding conductor is to be connected at the rear panel terminal provided, and connected to earth in a manner that will retain the earth connection when the power supply cord is unplugged. The connection to earth of the supplementary grounding conductor shall be in compliance with the appropriate rules for terminating bonding jumpers in Part V of Article 250 of the National Electrical Code, ANSI/NFPA 70, and Section 10 of Part I of the Canadian Electrical Code, Part I, CSA C22.1.

4.7.3 Ground Conductor Termination

Termination of the supplementary equipment grounding conductor may be made to building steel, to a metal electrical raceway system, or to any grounded item that is permanently and reliably connected to the electrical service equipment earth.

4.7.4 Ground Conductor Type

Bare, covered or insulated grounding conductors are acceptable. A covered or insulated grounding conductor shall have a continuous outer finish that is either green, or green with one or more yellow stripes.

4.8 Power Supplies

A single power supply for AC is standard, Figure 4-4, but available as an option is a redundant supply version shown in Figure 4-5. The following points must be taken into account when installing the Device and connecting power.

4.8.1 AC Power Supplies

Both the standard single power supply and the optional redundant AC power supplies are auto-sensing switching type power supply systems which may be operated on input voltages from 115 VAC to 230 VAC. There is no need to configure the power supplies to operate on any voltage in this range. Power cords appropriate to the locale where the unit is shipped are supplied.

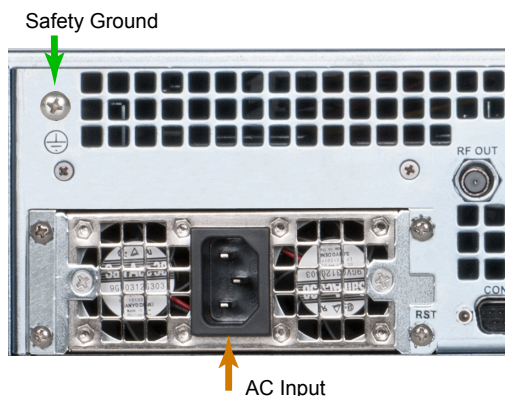

Figure 4-4: Single AC Power Supply

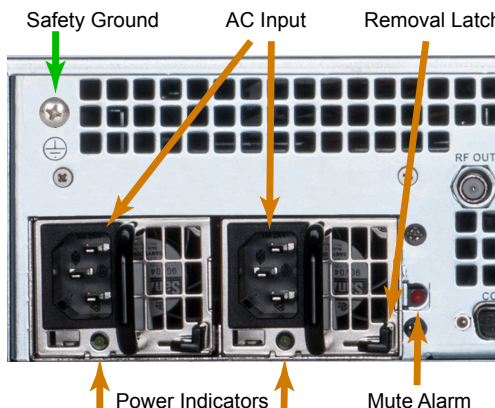

Figure 4-5: Redundant AC Power Supply

4.8.2 Power Supply Redundancy

For the redundant power supply option, either power module on its own can provide the required power safely if one fails. To retain the redundancy feature, replace a failed power module as soon as possible. A power module failure or the failure of the supply current or protection fuse will be indicated by an audible alarm within the encoder power modules and the green power status LED on the power module will be extinguished. Silence the audible alarm with the red rear panel **Alarm Reset** switch adjacent to the power supply modules, Figure 4-5.

4.8.3 Redundant Power Module Replacement



NOTE: The power cords for **BOTH** power modules must be disconnected before attempting to remove the power modules or otherwise servicing the unit.

Power module failure will be indicated by the alarm being sounded and the green status light on the module will no longer be lit. This power module may be replaced by first disconnecting the AC power cord from the IEC input socket of **BOTH** power modules, then release the module by pressing down on the thumb latch at the top of each module. Extract the module and replace with an identical replacement module only.

4.8.4 Power Cord Protection

Measures must be taken during installation to route or arrange the power supply cords or wires to prevent physical damage and to avoid the possibility of future damage occurring. The cords shall be installed and routed such that, throughout its length, the cord and its points of connection are not strained in any way.

4.8.5 Power Cord Attachment

The unit AC power supply cords shall not be attached to a building surface, bundled with audio, video or RF coaxial cables, nor run through walls, ceilings, floors and similar openings in the building structure.

4.8.6 Provision of Electrical Power Outlet

An AC electrical power outlet of appropriate type and rating shall be provided near the location where the unit is installed and easily accessible such that the provided power supply cords may be routed in an appropriate manner, without the use of extension cords, between the receptacle and the chassis. Alternately, the chassis shall be installed in close proximity to an existing AC electrical outlet such that the requirements of this paragraph are achieved.

4.8.7 IEC Power Input Cord for AC

The AC power input receptacle is a standard IEC connector similar to that commonly used on computers and monitors. The power cords provided with the product is a North American configuration with a NEMA 5-15 grounded plug for 115 VAC. If it is necessary to operate the product on 230 VAC, the installer must obtain IEC cords with a NEMA 6-15 grounded plug for use in North America. This may be obtained at time of order from ATX Networks or locally. If shipped outside of North America, the encoder will be supplied with an IEC cord set appropriate for the locale to which it is shipped.

4.8.8 Input Power Requirements

When installing the equipment, it is the responsibility of the installer to determine that sufficient capacity is available in the electrical circuit feeding the unit to avoid overloading the supply circuit. The AC model will require power to be supplied from a properly grounded AC outlet. The installer shall determine that the AC power outlet, its wiring and receptacle is in compliance with local and/or national electrical codes as applicable. The AC input power requirement is constant over the range of input voltages. At higher input voltages, the current consumption is lower than it is at lower voltages where the input current is higher.

4.8.9 Fusing

Internal over-current protection is built in to the power modules. There is no internal fuse to be replaced or maintained on either the single or redundant versions.

4.9 Ethernet Cabling

4.9.1 Management Port (eth0)

The rear panel Management Interface port eth0 allows connection to a notebook or desktop PC for managing and configuring the GUI. The port may be connected to directly, or in the case of a headend with many devices to manage, may be connected to a management network (recommended) or the distribution switch containing the video stream content. Connections should be made with Cat5e or better network cables. The 10/100 Base-T management ports is auto-negotiating and should be connected to a switch or router with a straight through wired cable. Direct connection to a PC may be made with the supplied crossover cable.

4.9.2 Ethernet Streaming Ports (eth1, eth2, eth3, eth4, eth5)

The ports are auto-negotiating and intended to be connected to a network distribution switch using straight through wired Cat5e or better quality cable. The 10/100/1000 Base-T ports negotiate an appropriate connection speed dependant on the type of external port it is connected to. DigiStream Lite models only have the ports eth0 and eth1.

STARTUP

5. Startup

Each of the Device chassis are factory configured identically with the standard ATX Networks default IP address of 192.168.0.23 assigned to port ETH0 (MGMT). Before connecting each Device to the management switch, the IP addresses must be re-configured for your network.



NOTE: This equipment must have default ETH0 port IP addresses changed from 192.168.0.23 before operation is initiated.



NOTE: It is important to connect the eth1, eth2, eth3, eth4 & eth5 streaming ports to a **GbE capable switch** or risk uncontrolled continuity errors as a connected 100 Base-T network may be flooded.



NOTE: It is important to connect the **eth1 streaming port to the TSoIP** with the provided cable if the device is provided with QAM output. This is the connection between the output streams and the QAM Modulator. Do not use eth1 for connection to any external networks.

5.1 Management Computer

It is required that the Management Computer meet these minimum requirements.

- Wired Ethernet network port.
- Web browser for Management GUI on 192.168.0.23.

5.2 Connecting to Your Computer

The DigiVu II and DigiStream rear panels have ETH0 (MGMT) network ports factory assigned IP address **192.168.0.23**, Figure 5-1. Configure your PC to connect to the GUI on this address.

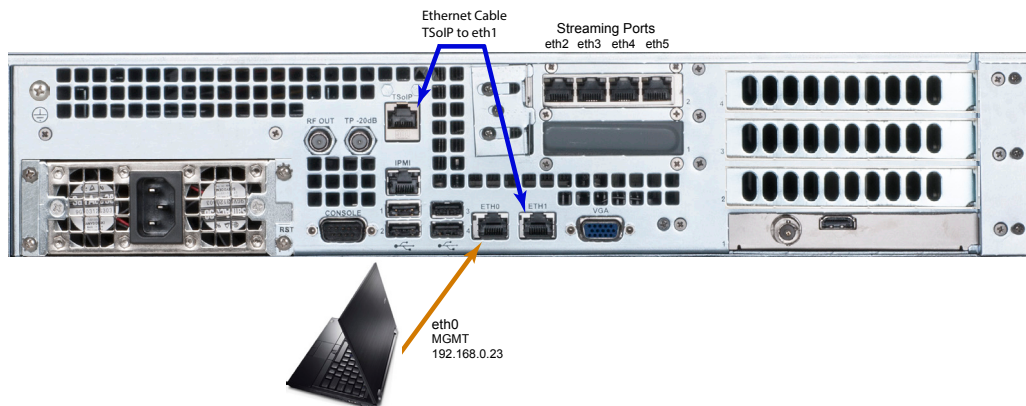

Figure 5-1: Rear Panel MGMT Port - 192.168.0.23



Note: Please refer to the **GUI Operation Manual** for programming guidance.

This page intentionally left blank.

SAFETY

6. Safety

WARNING! FAILURE TO FOLLOW THE SAFETY PRECAUTIONS LISTED BELOW MAY RESULT IN PROPERTY DAMAGE OR PERSONAL INJURY. PLEASE READ AND COMPLY WITH THE FOLLOWING:

SAFETY GROUND: The connection to earth of the supplementary grounding conductor, if provided, shall be in compliance with the appropriate rules for terminating bonding jumpers in Part V of Article 250 of the National Electrical Code, ANSI/NFPA 70, and Section 10 of Part I of the Canadian Electrical Code, Part I, CSA C22.1.

GROUNDING OR POLARIZATION: Electrical cord grounding and polarization means must not be defeated.

WATER AND MOISTURE: Care should be taken to prevent entry of splashed or dripping water, other liquids, and physical objects through enclosure openings.

DAMAGE: Do not operate the device if damage to any components is suspected.

POWER SOURCES: Only connect the unit to a power supply of the type and capacity specified in the operating instructions or as marked on the device.

NOTE: a) For 115 VAC operation, use the power cord supplied for operation from a 115 VAC source.

b) For 230 VAC operation, use the power cord supplied for operation from a 230 VAC source.

c) For DC operation, use insulated power leads of #12 AWG stranded wire for operation on -40 to -72 VDC

POWER CORD PROTECTION: Power supply cords should be routed so that they are not likely to be pinched by items placed upon or against them, paying particular attention to cords at plugs, convenience receptacles, and the point where they exit from the device.

SERVICE: Do not attempt to service the device beyond procedures provided in the operating instructions. All other servicing should be referred to qualified service personnel.

MODIFICATIONS: Modifications should not be made to the device or any of its components for applications other than those specified in the operating instructions.

SAFETY CODES AND REGULATIONS: The device should be installed and operated in compliance with all applicable local safety by-laws, codes and regulations.

REDUNDANT POWER SUPPLY REMOVAL: Power must be disconnected from the BOTH power modules before removing for replacement or service. This is accomplished by removing both of the AC IEC plugs or operating the DC power disconnects.

BATTERY REMOVAL AND REPLACEMENT: Disconnect all power sources (AC or DC) from the equipment before battery removal and replacement. This is accomplished by unplugging the AC power cords from the power outlet or operating the DC disconnects. Replace the battery with part No. CR2032 or exact replacement only.

CAUTION: Risk of explosion if battery is replaced by and incorrect type.

BATTERY DISPOSAL: Recycle or dispose of batteries in accordance with the battery manufacturer's instructions and local/national disposal and recycling regulations. Please call 1-800-8-BATTERY (1-800-822-8837) or go to the website at www.call2recycle.org in the US or www.call2recycle.ca in Canada for information on recycling or disposing of your used battery.

This page intentionally left blank.

SERVICE & SUPPORT

7. Service & Support

7.1 Contact ATX Networks

Please contact ATX Technical Support for assistance with any ATX products. Please contact ATX Customer Service to obtain a valid RMA number for any ATX products that require service and are in or out-of-warranty before returning a failed module to the factory.

DIGITAL VIDEO TECHNICAL SUPPORT

Tel: (905) 428-6068

Toll Free: (800) 565-7488 (USA & Canada only)

► Press *3 for **Technical Support**

► Then press 1 for **Digital Video Products (DVIS, DigiVu, UCrypt, VersActivePro, DigiStream)**

Email: digitalvideosupport@atxnetworks.com

CUSTOMER SERVICE

ATX Networks

1-501 Clements Road West

Ajax, ON L1S 7H4 Canada

Tel: (905) 428-6068

Toll Free: (800) 565-7488 (USA & Canada only)

► Press *1 for **Customer Service**

Fax: (905) 427-1964

Toll Free Fax: (866) 427-1964 (USA & Canada only)

Web: www.atxnetworks.com

Email: support@atxnetworks.com

7.2 Warranty Information

All of ATX Networks' products have a 1-year warranty that covers manufacturer's defects or failures.



End-of-Sale as of
March 31, 2017



1-501 Clements Road West, Ajax, ON L1S 7H4 Canada
Tel +1 (905) 428-6068 Toll Free +1 (800) 565-7488
Fax +1 (905) 427-1964 Toll Free Fax +1 (866) 427-1964
www.atxnetworks.com support@atxnetworks.com